



DIN RAIL EQUIPMENT ENCLOSURES

MCBs, RCDs, RCBOs



P. 14
RX³ MCBs up to
63 A, **6000**

Voltage surge protectors & other control and signalling devices



P. 22
Voltage surge
protectors

Time & light sensitive switches



P. 32
Light sensitive
switches

Full load switch units, supply busbars & distribution blocks



P. 37
Full load switch
units

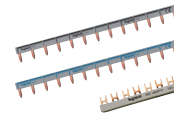

P. 42
Supply busbars

Distribution boards



P. 43
Consumer unit

NEW PRODUCTS



CX³ power contactors
(p. 26)



P. 15
DX³ MCBs up to 63 A, [10000] / 16 kA



P. 16
DX³ RCBOs up to 63 A, [6000] / 10 kA



P. 17
RX³ & DX³-ID RCDs up to 80 A, AC type



P. 26
CX³ power contactors



P. 28
Isolating switch



P. 29
Remote control dimmers



P. 33
Programmable time switches with digital display



P. 34
Programmable time switches with analog dial



P. 35
Wall mounting time switch



P. 36
Totalling hour counter

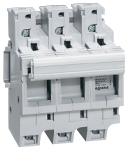

P. 38
SP fuse carriers



P. 39
Modular fuse carriers

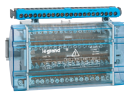

P. 40
Modular distribution blocks ≤ 250 A



P. 41
Power distribution blocks ≤ 400 A



P. 44
Mcb board

Supply busbars & distribution blocks

Standard or optimised distribution : choose the most convenient solution according to your needs

DISCOVER THE RANGE

- Standard distribution system : supply busbars and modular distribution blocks up to 250 A
- Optimised distribution system : time saving thanks to automatic or plug-in terminals, up to 125 A

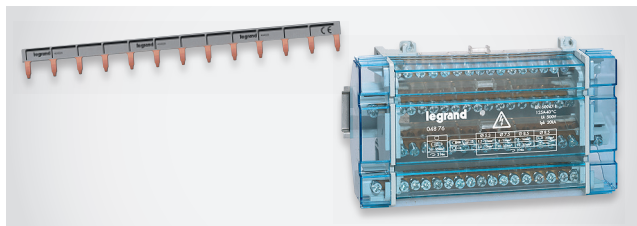

▶▶▶ Standard distribution system, p. 40

+ MORE INFORMATION



▶ www.legrand.com



▶ www.legrand-copytracer.com

MCBs RX³ 6000

thermal magnetic MCBs from 6 A to 63 A B and C curves



4 023 14



4 023 38

Dimensions **see e-catalogue**

Conform to IEC 60898-1
Do not accept auxiliaries, and add-on modules
Breaking capacity:
6000 - IEC 60898-1 - 230/400 V~
6 kA - IEC 60947-2 - 230/400 V~
10000 - IEC 60898-1 - 127/220 V~
10 kA - IEC 60947-2 - 127/220 V~

Pack	Cat.Nos		Single pole 230/400 V~	
	B curve	C curve	Nominal rating In (A)	Number of modules
10	4 022 70	4 023 10	6	1
10	4 022 71	4 023 11	10	1
10	4 022 72	4 023 13	16	1
10	4 022 73	4 023 14	20	1
10	4 022 74	4 023 15	25	1
10	4 022 75	4 023 16	32	1
10	4 022 76	4 023 17	40	1
10	4 022 77	4 023 18	50	1
10	4 022 78	4 023 19	63	1

Pack	Cat.Nos		2-pole 230/400 V~	
	B curve	C curve	Nominal rating In (A)	Number of modules
5	4 022 80	4 023 21	6	2
5	4 022 81	4 023 22	10	2
5	4 022 82	4 023 24	16	2
5	4 022 83	4 023 25	20	2
5	4 022 84	4 023 26	25	2
5	4 022 85	4 023 27	32	2
5	4 022 86	4 023 28	40	2
5	4 022 87	4 023 29	50	2
5	4 022 88	4 023 30	63	2

Pack	Cat.Nos		3-pole 400 V~	
	B curve	C curve	Nominal rating In (A)	Number of modules
1	4 022 90	4 023 32	6	3
1	4 022 91	4 023 33	10	3
1	4 022 92	4 023 35	16	3
1	4 022 93	4 023 36	20	3
1	4 022 94	4 023 37	25	3
1	4 022 95	4 023 38	32	3
1	4 022 96	4 023 39	40	3
1	4 022 97	4 023 40	50	3
1	4 022 98	4 023 41	63	3

MCBs DX³ 10000 - 16 kA

thermal magnetic circuit breakers from 6 A to 63 A



4 088 69



4 089 43



4 091 11



4 092 03



4 092 57

Dimensions **see e-catalogue**
 Technical characteristics **see p. 18**

Conform to IEC 60898-1
 Breaking capacity
 10000 - IEC 60898-1 - 400 V~
 16 kA - IEC 60947-2 - 400 V~
 Can be equipped with DX³ auxiliaries and accessories (Please consult us)

Pack	Cat.Nos		MCBs DX ³ 10000 - 16 kA	
	B curve	C curve	Nominal rating (A)	Number of modules
1	4 088 69	4 091 11	6	1
1	4 088 70	4 091 12	10	1
1	4 088 71	4 091 13	13	1
1	4 088 72	4 091 14	16	1
1	4 088 73	4 091 15	20	1
1	4 088 74	4 091 16	25	1
1	4 088 75	4 091 17	32	1
1	4 088 76	4 091 18	40	1
1	4 088 77	4 091 19	50	1
1	4 088 78	4 091 20	63	1

Pack	Cat.Nos		MCBs DX ³ 10000 - 16 kA	
	B curve	C curve	Nominal rating (A)	Number of modules
1	4 089 88	4 092 51	6	3
1	4 089 89	4 092 52	10	3
1	4 089 90	4 092 53	13	3
1	4 089 91	4 092 54	16	3
1	4 089 92	4 092 55	20	3
1	4 089 93	4 092 56	25	3
1	4 089 94	4 092 57	32	3
1	4 089 95	4 092 58	40	3
1	4 089 96	4 092 59	50	3
1	4 089 97	4 092 60	63	3

Pack	Cat.Nos		2-pole 230/400 V~	
	B curve	C curve	Nominal rating (A)	Number of modules
1	4 089 39	4 091 99	6	2
1	4 089 40	4 092 00	10	2
1	4 089 41	4 092 01	13	2
1	4 089 42	4 092 02	16	2
1	4 089 43	4 092 03	20	2
1	4 089 44	4 092 04	25	2
1	4 089 45	4 092 05	32	2
1	4 089 46	4 092 06	40	2
1	4 089 47	4 092 07	50	2
1	4 089 48	4 092 08	63	2

Pack	Cat.Nos		4-pole 400 V~	
	B curve	C curve	Nominal rating (A)	Number of modules
1	4 090 62	4 093 33	6	4
1	4 090 63	4 093 34	10	4
1	4 090 64	4 093 35	13	4
1	4 090 65	4 093 36	16	4
1	4 090 66	4 093 37	20	4
1	4 090 67	4 093 38	25	4
1	4 090 68	4 093 39	32	4
1	4 090 69	4 093 40	40	4
1	4 090 70	4 093 41	50	4
1	4 090 71	4 093 42	63	4

DX3 Mcbs D curve and up to 125A
Please, consult us



RCDs RX³ and DX³-ID

residual current circuit breakers from 25 A to 80 A AC types

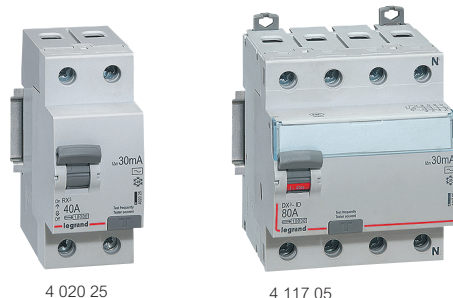

4 020 25

4 117 05

Dimensions **see e-catalogue**
 Technical characteristics for DX³-ID **see opposite**

Conform to IEC 61008-1

- AC type : detect AC component faults
 - DX³-ID RCD enhanced immunity to unwanted tripping in disturbed environments
- Can be equipped with DX³ auxiliaries and accessories (please consult us)

Pack	Cat.Nos	RX ³ RCDs	
		2-pole - 230 V\sim	
		AC type 30 mA	
		In (A)	Number of modules
1	4 020 24	25	2
1	4 020 25	40	2
1	4 020 26	63	2
1	4 020 27	80	2
		AC type 300 mA	
1	4 020 32	25	2
1	4 020 33	40	2
1	4 020 34	63	2

Pack	Cat.Nos	DX ³ -ID RCDs	
		4-pole - 400 V\sim - neutral on right-hand side	
		AC Type 30 mA	
		Nominal rating In (A)	Number of modules
1	4 117 02	25	4
1	4 117 03	40	4
1	4 117 04	63	4
1	4 117 05	80	4
		AC Type 300 mA	
1	4 117 22	25	4
1	4 117 23	40	4
1	4 117 24	63	4
1	4 117 25	80	4

RCDs DX³-ID

technical characteristics

■ DX³-ID - RCDs (residual current devices)

Connection cross-section

RCDs	Cable (mm ²)	
	rigid	flexible
Connection at top and bottom	50	35

■ AC type - Standard applications

AC type RCDs detect AC residual currents
 In the majority of cases (standard applications), they are used for AC current detection at 50/60 Hz

Performance of MCBs and RCBO

■ Breaking capacity in IT neutral earthing system

MCB single pole breaking capacity at 400 V according to IEC 60947-2

DX ³ 10000 16 kA	1P/2P/3P/4P	4 kA
DX ³ 25 kA	1P/2P/3P/4P	6.25 kA
DX ³ 36 kA	2P/3P/4P	9 kA
DX ³ 50 kA	1P/2P/3P/4P	12.5 kA

■ Breaking capacity in the event of short-circuit to earth and insulation voltage

	1P/2P/3P/4P 230/400 V~ MCBs			
	DX ³ 10000 16 kA	DX ³ 25 kA	DX ³ 36 kA	DX ³ 50 kA
Icn1	16000 A	25000 A	36000 A	50000 A
Ui	500 V	500 V	500 V	500 V

Icn 1: Breaking capacity on 1 pole for multipole MCBs in the event of short-circuit to earth

Ui: Rated insulation voltage

■ Terminal connection cross-sections (mm²)

Copper cable	Rigid	Flexible
	DX ³ 6000 10 kA	35
DX ³ 10000 16 kA	70	50
DX ³ 80 to 125 A		
DX ³ 25 kA ≥ 32 A (C curve) ≥ 16 A (D curve)	50	35
DX ³ 36 kA, DX ³ 50 kA and add-on modules		
Auxiliaries	2.5	2.5

■ MCB tripping curves

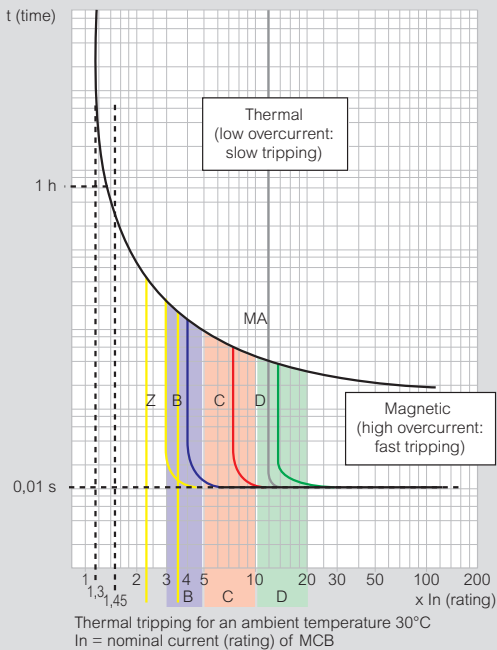

Curves	Magnetic threshold settings
Z ⁽¹⁾	2.4 to 3.6 In
B	3 to 5 In
C	5 to 10 In
D	10 to 14 In (10 to 20 acc. to the stds)
MA ⁽¹⁾	12 to 14 In

1: On request

■ Technical characteristics of auxiliaries

Max. connection cross-section: 2.5 mm²
Operating temperature: - 25°C to + 70°C

Shunt trips

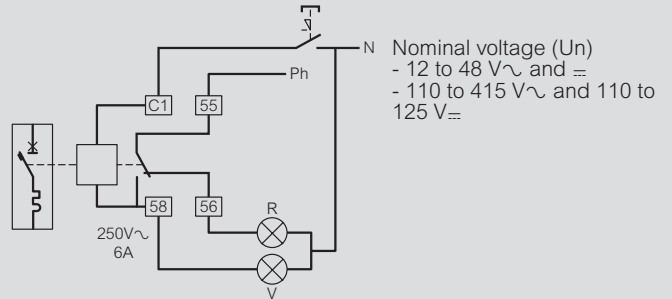

Equipped with a signalling contact which indicates tripping of the shunt trip and automatically breaks the coil.

Min. and max. voltage: 0.7 to 1.1 Un

Tripping time: less than 20 ms

Power consumption: at 1.1 x 48 V = 121 VA
at 1.1 x 415 V = 127 VA

Impedance: 12 to 48 V = 23 Ω
110 to 415 V = 1640 Ω

Consumption	Umin.	Umax.
12 to 48 V	522 mA	2610 mA
110 to 415 V	69 mA	259 mA

Undervoltage releases

Pull-in voltage ≥ 0.55 Un

Tripping time: 100 to 400 ms ± 10% (adjustable)

Power consumption: 24 V~ and =: 0.1 VA
48 V~ and =: 0.2 VA
230 V~: 1 VA

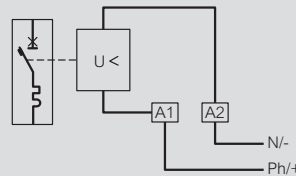

Stand-alone releases for N/C push-buttons

Min. and max. operating voltage: 196 to 250 V~
Power consumption: 1.4 VA

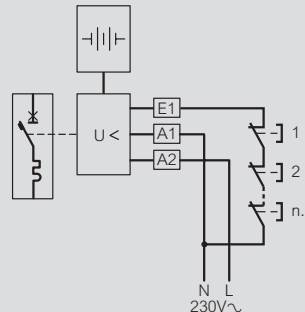

Signalling auxiliaries

Umin.: 24 V~/= and Imin.: 5 mA

Average residual current performance curves

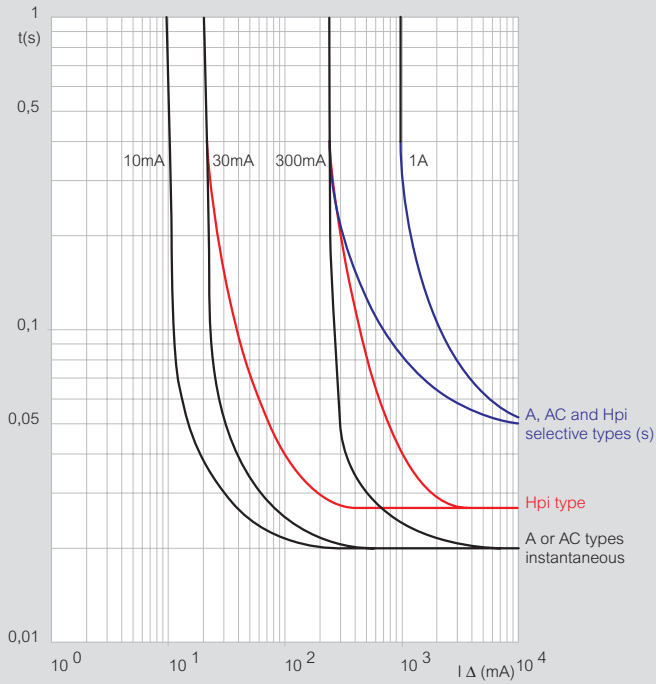

Residual current breaking capacity of DX³ add-on modules

$I_{\Delta m}$ according to EN 61009-1
AC, A and Hpi add-on modules

DX ³ add-on modules used with an MCB		$I_{\Delta m}$
DX ³ (1 mod./pole)	25 kA ≤ 25 A (B, C, Z curves)	6000 A
	25 kA ≤ 10 A (D, MA curves)	
DX ³ (1.5 mod./pole)	16 kA (80 to 125 A)	30000 A
	25 kA ≥ 32 A (B, C, Z curves)	
	25 kA ≥ 12.5 A (D, MA curves)	
	36 kA	
	50 kA	

DXTM RCBOs single pole

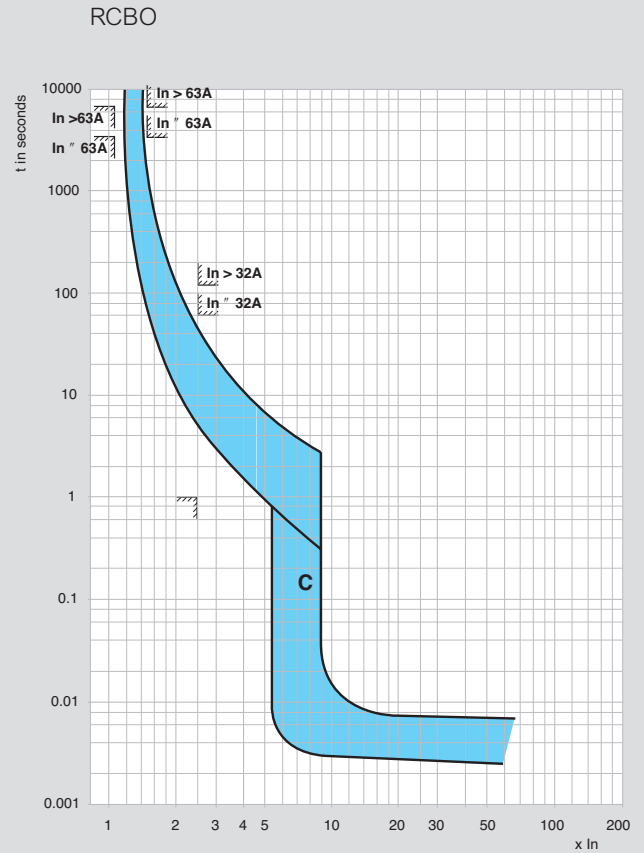

Protection of DC circuits

DX³ 6000 and DX³ 10000 MCBs (1P/2P/3P/4P - $I_n \leq 63$ A) designed for use in 230/400 V \sim supplies, can also be used in DC circuits. In this case, the following deratings and precautions must be taken into account:

1 - Protection against short-circuits

Max. magnetic tripping threshold: multiplied by 1.4
 Example: For a C curve MCB for which the AC tripping threshold is between 5 and 10 I_n , the DC tripping threshold will be between 7 and 14 I_n .

2 - Protection against overloads

The time/current thermal tripping curve is the same as for AC.

3 - Operating voltage

Max. operating voltage: 80 V per pole (60 V for single-pole + N MCBs). For voltages higher than this value, several poles must be wired in series.

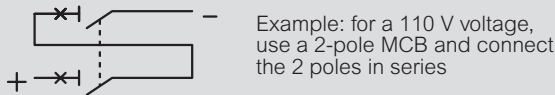

4 - Breaking capacity

4000 A for a single pole MCB at max. voltage (80 V \sim per pole).

For other voltages, the breaking capacities are as follows:

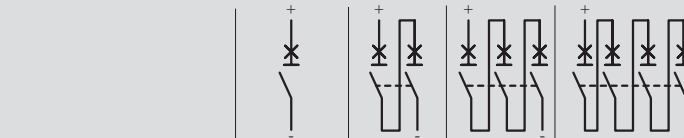

DX ³ 6000	voltage	single-pole	2P	3P	4P
Acc. to IEC 60947.2	≤ 48 V	6 kA	6 kA		
	110 V		6 kA	6 kA	
	230 V				10 kA
Ics ⁽¹⁾	≤ 48 V	100 %	100 %		
	110 V		100 %	100 %	
	230 V				100 %

DX ³ 10000	voltage	single-pole	2P	3P	4P
Acc. to IEC 60947.2	≤ 48 V	10 kA	10 kA		
	110 V		10 kA	10 kA	
	230 V				15 kA
Ics ⁽¹⁾	≤ 48 V	100 %	100 %		
	110 V		100 %	100 %	
	230 V				100 %

1: As a % of I_{cu}

5 - Distribution of breaking poles

To choose the MCB and determine the pole distribution necessary for breaking on each of the polarities, it is necessary to know how the installation is earthed.

• Supply with one polarity earthed:

Place all the poles necessary for breaking on the other polarity. If isolation is required, an additional pole must be added on the earthed polarity.

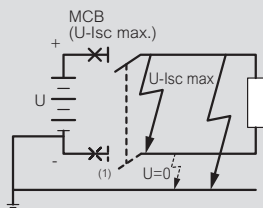

Example: circuit earthed via the negative polarity / $U = 110$ V \sim / $I_{sc} = 10$ kA / $I_n = 32$ A

Protect the positive polarity using an MCB capable of breaking 10 kA at 110 V (DX³ 10000 2P 32 A with 2 poles on the positive polarity). For isolation, use a DX³ 10000 3P 32 A with 2 poles on the positive polarity and one pole on the negative polarity.

DX ³ 10000	voltage	single-pole	2P	3P	4P
Acc. to IEC 60947.2	≤ 48 V	10 kA	10 kA		
	110 V		10 kA	10 kA	
	230 V				15 kA

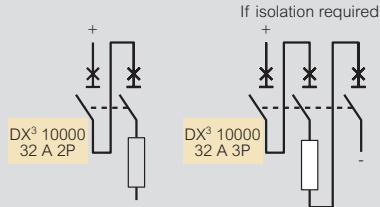

• Network earthed via a middle point:

Place on each polarity the number of poles necessary for max. I_{sc} breaking at half voltage.

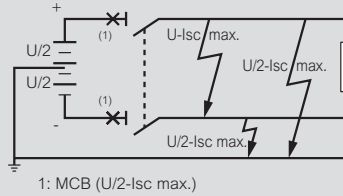

Example: circuit earthed via a middle point / $U = 230$ V \sim / $I_{sc} = 6$ kA / $I_n = 10$ A

Protect each polarity using an MCB capable of breaking 6 kA at half voltage, i.e. 115 V (DX³ 6000 4P 10 A with 2 poles on each polarity).

DX ³ 6000	voltage	single-pole	2P	3P	4P
Acc. to IEC 60947.2	≤ 48 V	6 kA	6 kA		
	110 V		6 kA	6 kA	
	230 V				10 kA

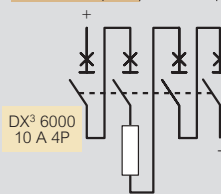

• Isolated earth supply:

Distribute the poles necessary for breaking over the 2 polarities to provide protection in the event of a double earth fault (particularly if there are a number of circuits in parallel).

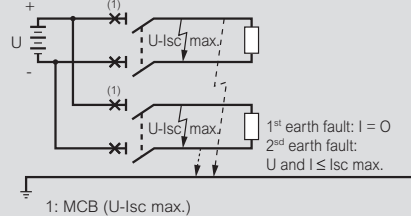

Example: isolated earth circuit / $U = 48$ V \sim / $I_{sc} = 4,5$ kA / $I_n = 40$ A. Protect the installation with an MCB capable of breaking 4.5 kA at 48 V and protect each polarity (DX³ 6000 MCB 2P 40 A with one pole on each polarity).

DX ³ 6000	voltage	single-pole	2P	3P	4P
Acc. to IEC 60947.2	≤ 48 V	6 kA	6 kA		
	110 V		6 kA	6 kA	
	230 V				10 kA

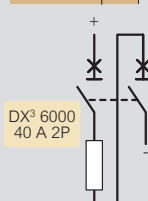

Selectivity tables

MCBs/MCBs (in A)

Downstream MCB	Upstream MCB												
	In (A)	RX ³ 6000 / DX ³ 10000 - 16 kA				RX ³ 6000 / DX ³ 10000 - 16 kA							
		B curve				C curve							
		32	40	50	63	32	40	50	63	80	100	125	
RX ³ 6000 B & C curve	≤ 6	128	160	200	252	240	300	375	472	1300	1600	2000	
	10	128	160	200	252	240	300	375	472	1150	1450	1800	
	13	128	160	200	252	240	300	375	472	1000	1300	1600	
	16	128	160	200	252	240	300	375	472	950	1200	1500	
	20		160	200	252	240	300	375	472	900	1100	1400	
	25			200	252	240	300	375	472	850	1000	1300	
	32				252		300	375	472	750	950	1200	
	40							375	472	700	850	1100	
	50								472	650	800	1000	
	63									650	800	1000	
DX ³ 10000 - 16 kA B & C curve	≤ 6	128	160	200	252	240	300	375	472	4000	T	T	
	10	128	160	200	252	240	300	375	472	3000	5000	T	
	16	128	160	200	252	240	300	375	472	2000	3600	5500	
	20		160	200	252	240	300	375	472	1600	3000	4000	
	25			200	252	240	300	375	472	1300	2400	3300	
	32				252		300	375	472	1000	1800	2700	
	40							375	472	800	1600	2400	
	50								472	800	900	1700	
	63									650	900	1200	
	80										600	750	
	100											750	
	125												

T: total selectivity, up to downstream circuit breaker breaking capacity according to IEC 60947-2
The magnetic threshold and the nominal rating of the downstream MCB must always be inferior to the ones of the upstream MCB